



PO Box 128

| 504 Highway 63 South

| Freeburg, MO 65035

| 800-347-0438

| 573-469-4151 (fax)

Installation Guidelines for all Quaker Products With Flange Fin Sub-Sill and Receptor with T-mullion

Read these instructions completely before starting any installation. Failure to install and maintain our product according to these instructions may void any product warranty. Please visit our website at www.quakerwindows.com or call 1-800-347-0438 for additional information.

Tools required by installer:

Safety Glasses		Utility Knife	
Drill/Driver		Caulk Gun	
Level		Tape Measure	
Rubber Mallet		J-Roller	
Metal Cutting Saw		Staple Gun	

Materials required by installer:

Foam Backer Rod		Minimally Expanding Foam	
Shims (Waterproof)		Sealant	
Flashing tape (Self-Adhering)		Water Resistant Barrier/House Wrap (WRB)	
Fasteners		IPA Alcohol	

WARNING

Tools

- Follow manufacturer's instructions for safe operation of tools, and ladders/scaffolding. Always wear safety glasses. Failure to do so could result in injury, product or property damage.

Handling

- Do not store units outside, or in a hot environment. Doing so could result in product damage.
- Do not carry flat.** Doing so could result in product damage, injury, or property damage.
- Stack units as straight as possible to avoid bowing. **Do not lay flat!**

Glass

- If broken, glass can fragment causing injury. All Quaker products are available with safety glass. In many areas, local building codes require safety glass in certain locations and/or applications. Unless safety glass is ordered, Quaker windows are not provided with safety glass. Before ordering, consult your local building codes for more definitive information.

Fastening

- Metal fasteners and components could corrode when used with preservative-treated lumber. Use approved fasteners and components to fasten window or door. Failure to do so could cause a failure resulting in injury, product or property damage.
- Fastener must attach to a structural framing member with 1 1/2" minimum fastener embedment, or minimum 3 full threads with a minimum 5/16" head as products were tested with.
- Quaker does not supply anchorage/fastener calculations, and is not responsible for determining structural adequacy of the anchorage and fasteners used to install our products, or the openings into which they are installed.**
- Do not over drive screws or nails.** Doing so could result in product damage.

CAUTION**Installation**

- Always support window or door in opening until fully fastened. Failure to do so could result in the window or door falling out or causing injury, product, or property damage.
- Nailing flanges and drip caps (integral or applied) **do not** take the place of window flashing. All windows and doors must be properly flashed and sealed with material compatible sealant for protection against water and air infiltration around the entire perimeter. Failure to do so could result in product or property damage.
- **Do not** set window directly on sill plate. Place shims under the side jambs. Window or door must be properly shimmed. Failure to do so could affect operation and product performance and could result in product damage.
- Live or dead loads transferred into our product can affect functionality, damage frame joinery or cause glass failures. Dead loads such as upper levels, roof, etc. Should be constructed before window or door is installed.
- Loads shall be designed to withstand the most critical effects of load factors and load combinations as required by the building code. (Loads are including but not limited to Live, Dead, Collateral, Auxiliary, Thermally induced, Seismic, etc.)
- Maximum vertical deflection of the header under all Load combination should not exceed the Span/720 or 1/4" whichever is less.
- Windows and doors have small parts. Small parts if swallowed could pose a choking hazard to young children. Dispose of unused, loose, or easily removed small parts. Failure to do so could result in injury.
- **Do not** drill through or into window sill to install alarm wires.

Sealing

- Follow instructions of foam, sealant, and flashing manufacturers regarding safety, material application, compatibility, and periodic maintenance for continued weather resistance of their products. Failure to do so could result in product or property damage. **DO NOT** overfill between the frame and opening.
- Minimally expanding foam insulation must be compliant with AAMA 812-19.
- Quaker recommends 100% silicone (ASTM C920 compliant) neutral cure only sealant. Always clean all areas where sealant will be applied. Failure to do so could result in product or property damage.
- Flashing tape must meet ASTM-D779 performance requirements.
- Maintain a minimum of 1/4" between the window or door frame and exterior finish materials. Failure to do so could result in product or property damage.

Joining

- Do not join any window or door to any window or door not designed for joining. Joined windows and doors must be individually supported in the opening. Failure to do so could affect operation and product performance and could result in product or property damage.

Cleaning

- Acid solutions used for cleaning will damage glass, fasteners, hardware, and metal flashing. Protect these products and follow cleaning products manufacturers instructions. If acid contacts the window or door, wash all surfaces immediately with clean water.
- **Do not** use razor blades to clean glass surface. Glass damage could result.
- Clean glass using liquid glass cleaner.
- Clean frame, sash, panels, and insect screens using mild detergent and warm water with a soft cloth or brush.

IMPORTANT

- Buildings constructed prior to 1978 could contain lead paint which could be disturbed during window or door replacement. For more information on proper management of lead paint, go to: www.epa.gov/lead
- Care must be taken to properly recycle or dispose of old materials. Any recyclable materials should be separated from non-recyclable or hazardous materials. Please consult with local or state authorities regarding proper disposal of non-recyclable or hazardous materials.
- These are generic instructions intended to cover most common situations, which may not be appropriate for all installations due to building design, construction materials, or methods used and/or building or site conditions. Consult a contractor or architect for recommendations.
- Inspect all units for any damage or defects prior to installation. Contact the nearest Quaker distributor if there are any problems.

Quaker Supplied Parts:

Sub-sill

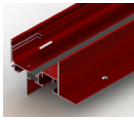

Receptor

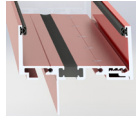

Wedge gasket

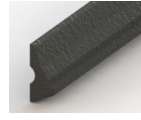

Corner gaskets

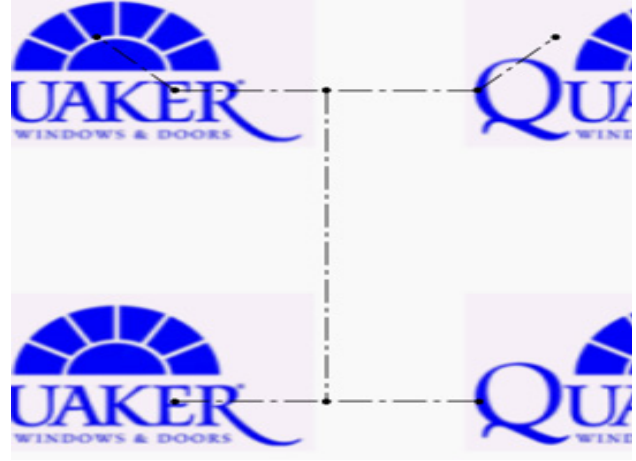
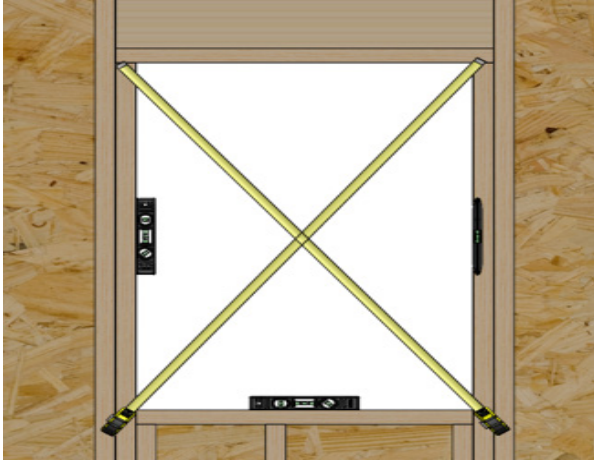
**1**

Measure and verify the size of the rough opening. The rough opening should be a minimum $\frac{1}{2}$ " (but not to exceed 1") wider and taller than your flanged sub-sill/receptor unit. Verify the rough opening is flat, plumb, level, and square. Take diagonal measurements to check for square. The sill plate beneath the unit must be level for proper unit operation. Cut the weather-resistant barrier (WRB) in a "I" pattern. Cut the top corners of the WRB at 135° and 9" long.

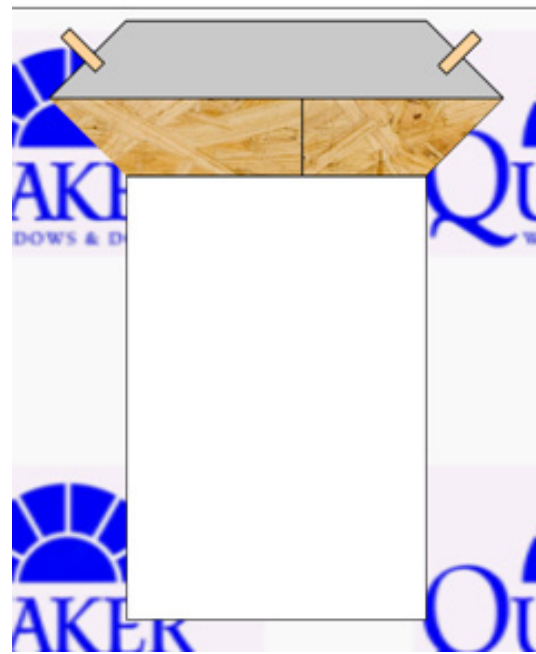
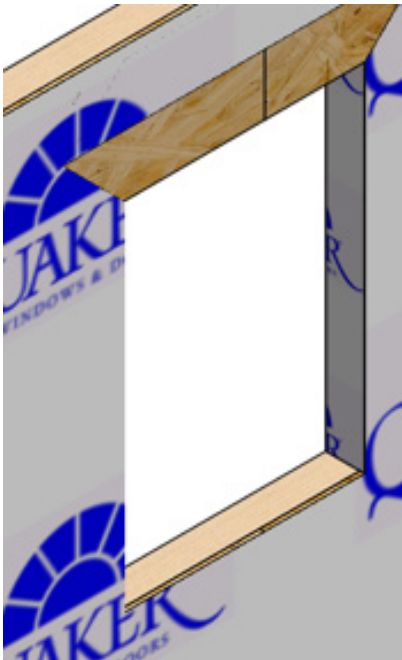
2

Fold back the WRB sides and sill toward the interior and staple into place. Fold flap up and temporarily tape in place as shown above.

3

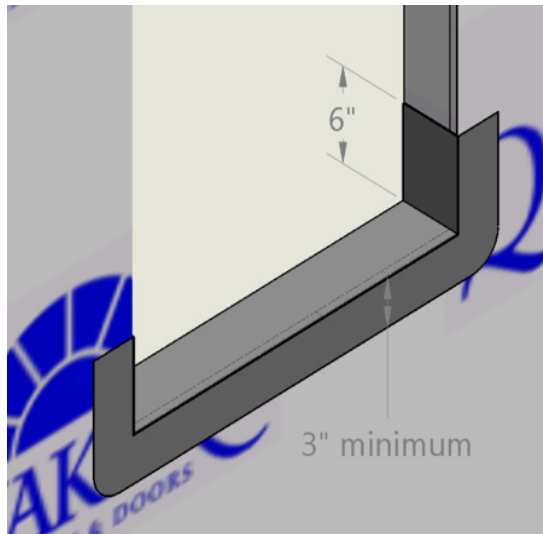

Measure the width of rough opening and cut a length of flashing that is 12" wider than the rough opening. This will allow you to run the flashing 6" up each side. Apply sill flashing to exterior side first allowing for a minimum of 3" of flashing to be below the sill, and a minimum of 6" up each side. Flashing tape must cover the entire sill plate. If needed, apply an additional flashing piece over the first one (start from the exterior and work toward the interior). Maintain a minimum 1" overlap

4

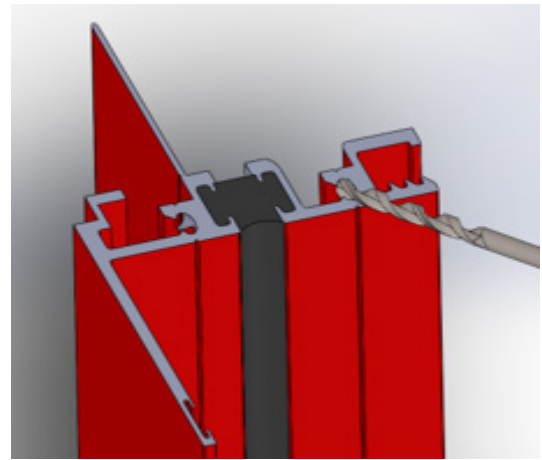

Measure the sill opening and square cut the sub-sill $\frac{1}{2}$ " less than opening to allow for level & shimming.

Cut the head the same as the sub-sill, but miter cut both ends at 45 degrees.

The jamb will be handed left and right and notched at the factory to fit the sub-sill. Measure the opening height and miter cut at 45 degrees the head side of jambs $1 \frac{1}{16}$ " less than opening to allow for leveling & shimming.

Note: when cutting all material use caution not to cut weather-strip to short.

Using the screw slots as a guide, cross drill the head end of the mitered receptor jamb with an $1 \frac{1}{64}$ " drill for corner assembly screws.

5

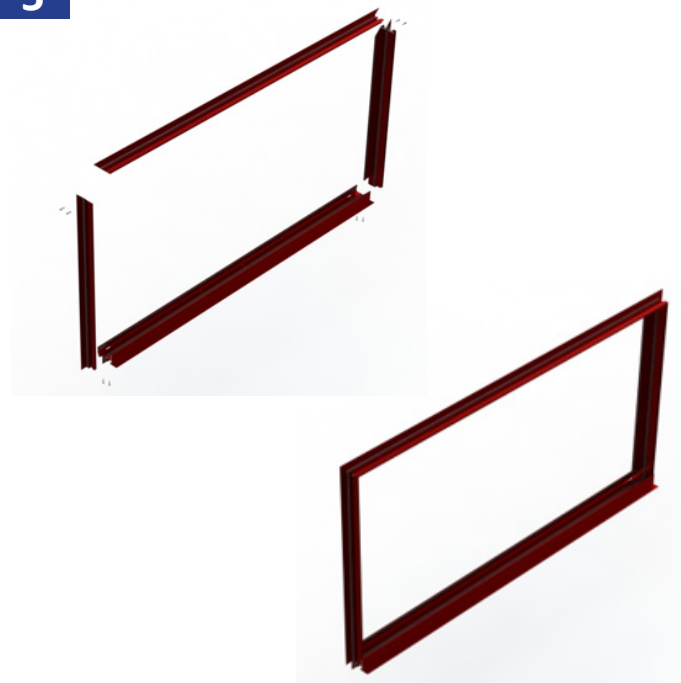

Assemble all four parts together with supplied screws using a total of 8 screws.

6

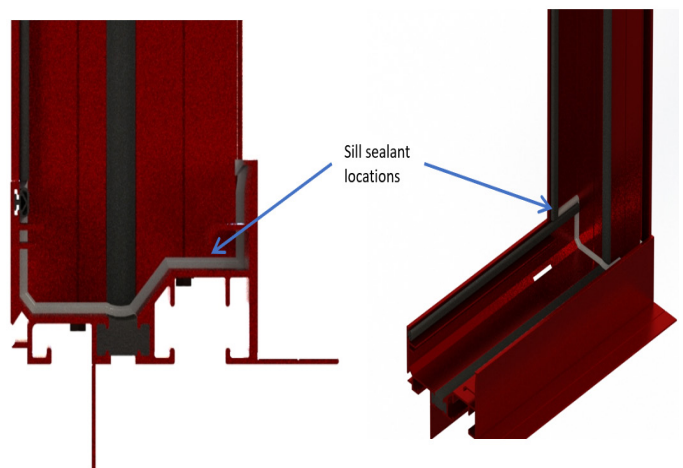

Apply sealant to both corners inside where the sub-sill and receptor come together covering all seams. Tool in if needed to fully fill in the joints.

7

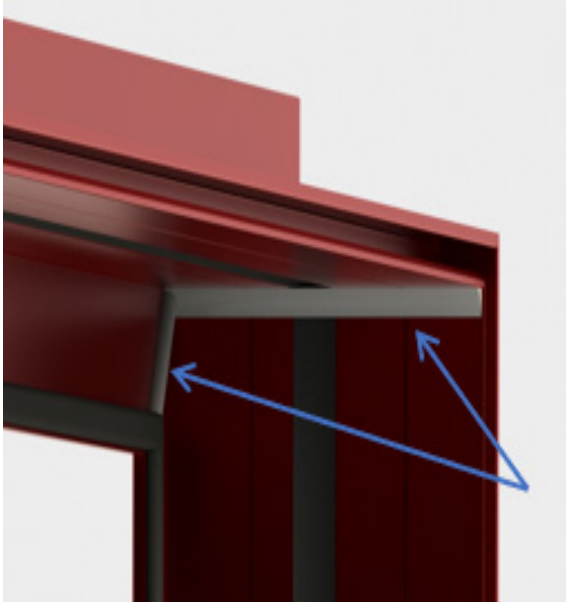

Apply sealant to both corners inside where the jamb and head receptors come together covering all seams. Tool in if needed to fully fill in the joints.

8

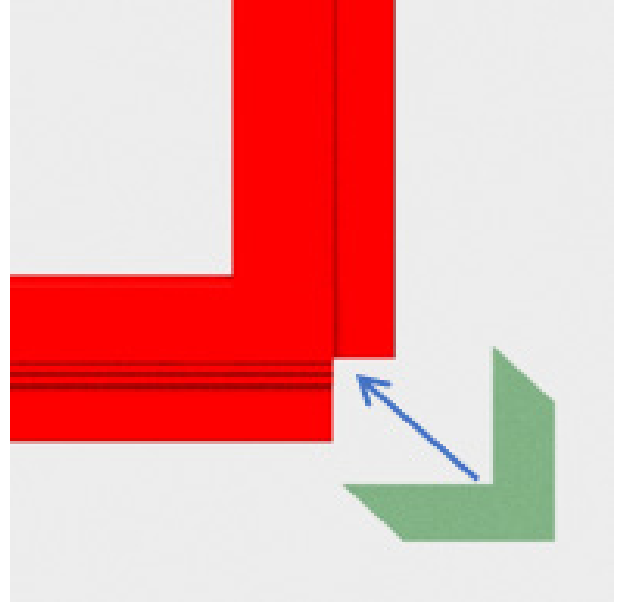

Peel backing off the supplied corner gaskets and install over exterior side of flashing flange on the bottom two corners to cover gap between flanges.

9

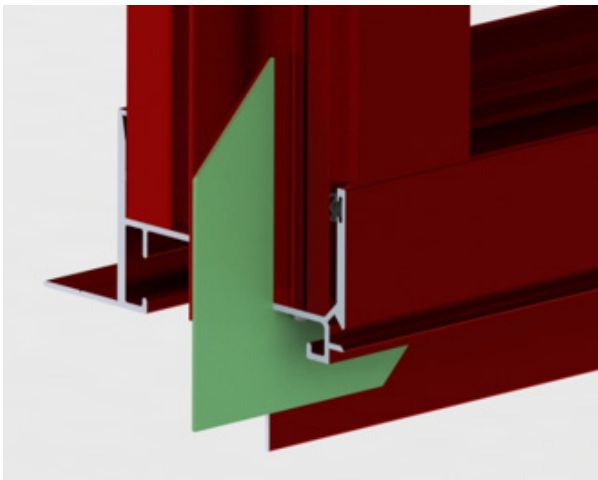

Apply sealant to cover any hole between gasket and frame.

10

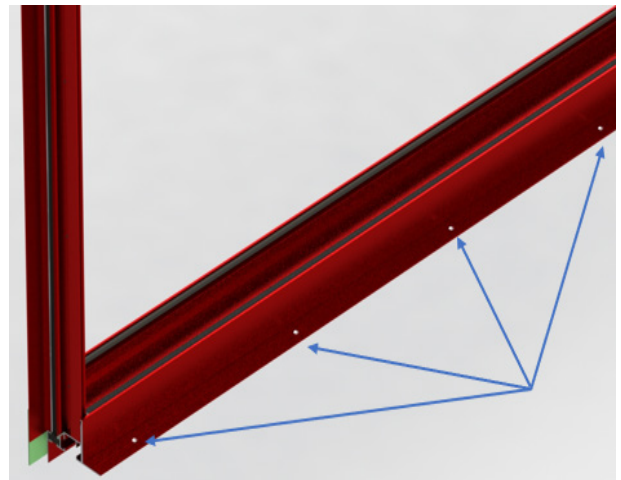

Test fit the flashing flange system into the opening to ensure a proper fit that is plumb, level, and square. Check and mark points in sub-sill anchor flange, jamb & head receptors for places to drill pilot holes for installation. Remove flashing flange system. Drill pilot holes in the interior sub-sill interior anchor flange per shop drawings or anchorage calculations. Typically 3" from the ends and 12" on center.

11

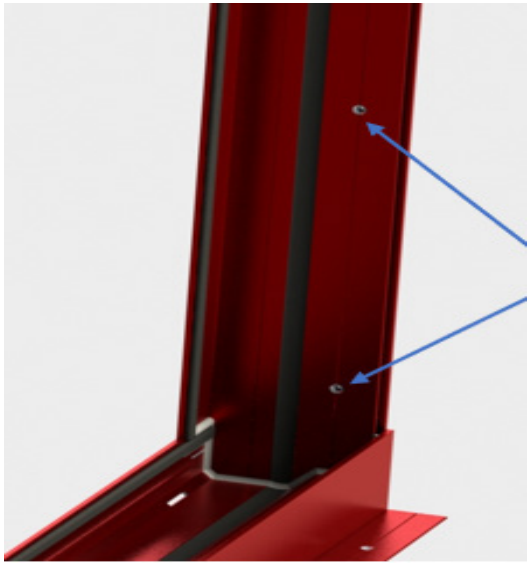

Drill pilot holes in the jamb and head receptor per shop drawings or anchorage calculations. Typically 3" from the corners and 12" on center. Keep all pilot holes on the interior side of flashing flange.

12



Apply a 3/8" diameter bead of sealant along the interior side of the flashing flange. Bead must run continuously around both sides and across the head.

13



Use a discontinuous bead at the sill to allow for any drainage. Alternate using a 6" long bead with 1" gaps as shown above.

14



Center and set the flashing flange system into the rough opening. Pulling the system tight towards the interior making sure flashing flange is tight against the WRB. Temporarily screw the window into place using a screw through the pre-drilled pilot holes on the sub-sill anchor flange. **Do not** screw through flashing flange.

15

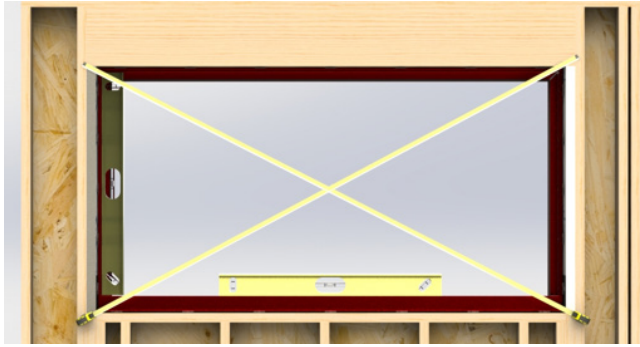

Square, plumb, and level the flange fin system into the opening shimming as needed at each fastener location.

16



Apply sealant in installation holes or on screws. Fasten the flange fin system to framing with screws by others per shop drawings or anchorage calculations.

17



Cut two pieces of flashing tape for jamb flashing extending 1" above flashing flange system head flange and 4" to 6" below bottom edge of sill flashing. Remove release paper and press tightly along sides of window frame.

18



Cut a piece of flashing tape for the head flashing, which extends beyond outer edges of jamb flashings. Remove release paper and install completely covering mounting flange and adhering to exposed sheathing or framing members.

19

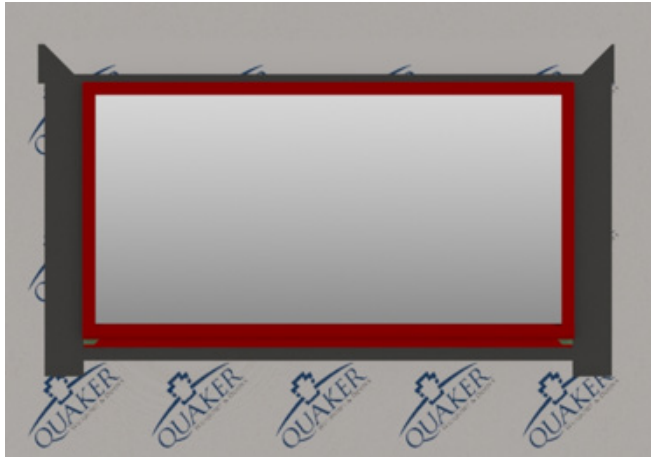

Flip down upper flap of WRB so it lays flat across head flashing, then trim 1"–2" above the window opening.

20



Tape along all cuts in WRB and across head of the window with flashing tape and tape both angle cuts.

21

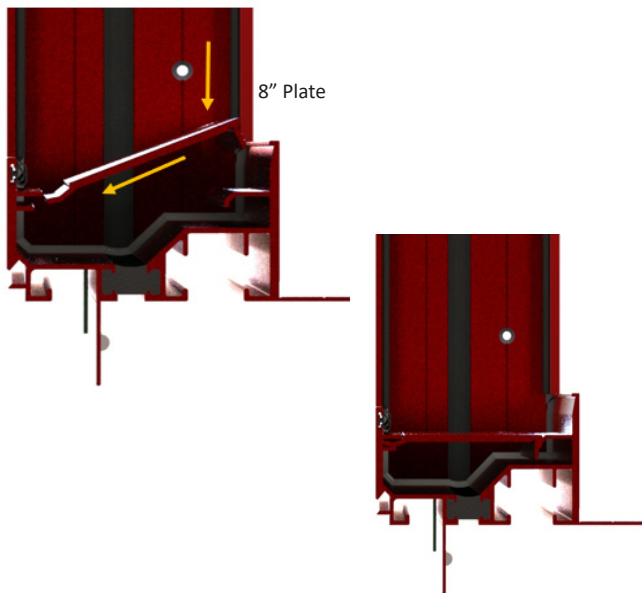

Install the 8" anchor plate in the center of the mullion location at an angle sliding the leg into the notch in the sub-sill, and then press the anchor plate down until it snaps into place.

22

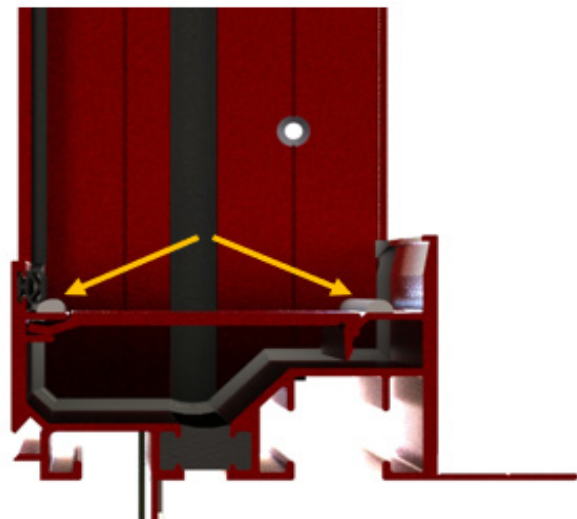

Apply a bead of sealant to the legs of the sub-sill where the window will rest.

23

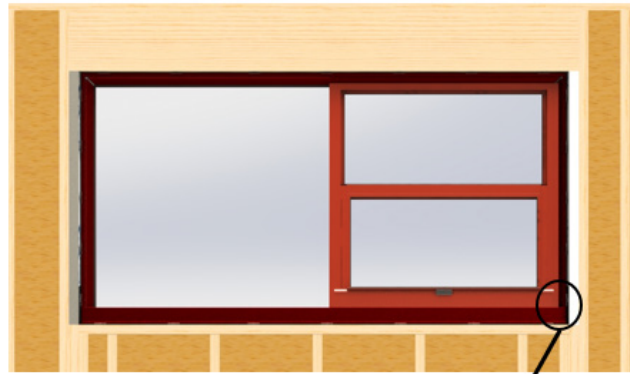

Measure the gap between window and receptor per shop drawings.



Install the first window in opening and set the interior leg of the window onto the sub-sill frame, then push the window head and jamb in against the head and jamb receptors. Measure to locate the window is the correct distant from the jamb receptor per shop drawings. Snap in temporary closer pieces to hold window into place. Place a level on the window sill to verify that the sill is level. Adjust the shims as needed to ensure a level condition.

24

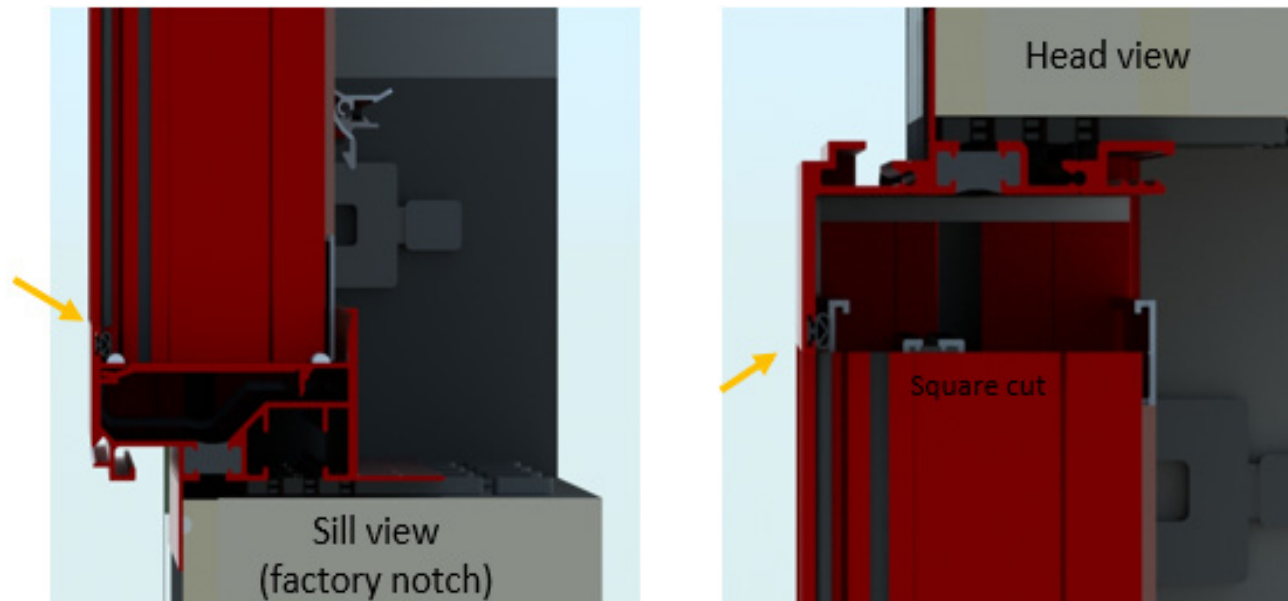

Measure between the exterior sub-sill and head receptor legs and square cut the T-mull head. Note: The T-mull sill should be notched on the exterior face from the factory.

25

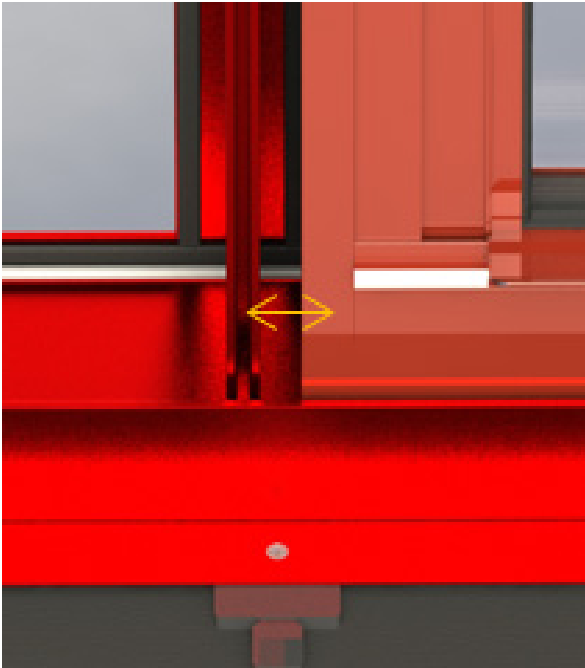

Measure to locate the spacing between the T-mull and window matches the shop drawings.

26



Install L-angles in a bed of sealant with self-tapping screws into anchor plate. Note: Make sure screw don't penetrate sub-sill. Secure the L-angle to the T-mull at the sill with same screws. Verify T-mull is vertical and secure L-angle to the head receptor and T-mull with self-tapping screws.

Install the next windows following the same steps in 22-23.

27

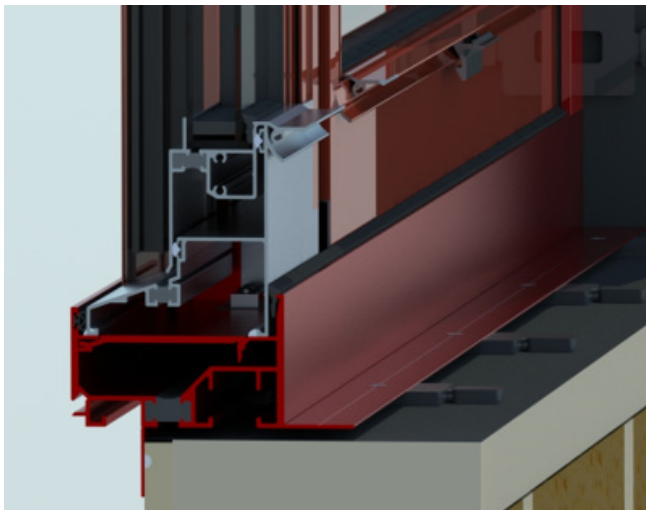

Apply the continuous sub-sill wedge gasket into the interior side of the sub-sill against the window.

28

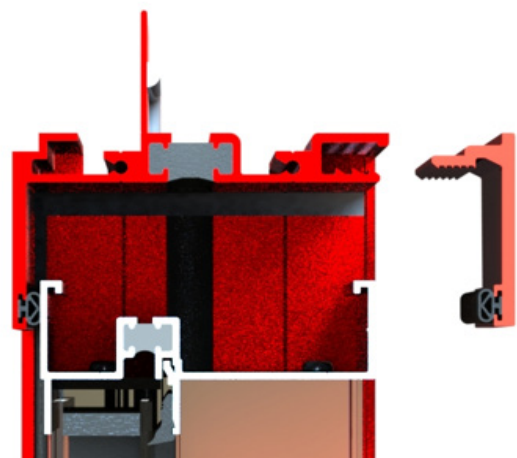

Measure opening and cut the head receptor closer clip. Trim weather strip to appropriate length using caution not to stretch material. Install clip using a rubber mallet to make sure the closer clip snaps into place.

Measure between the sub-sill and head receptor clip and cut the jamb receptor closer clips. Trim weather strip to appropriate length using caution not to stretch material. Install clip using a rubber mallet to make sure the closer clip snaps into place.

29



Check the installed product to ensure that it operates properly and that the reveal is equal between the sash and frame. Install T-mull base plate with weather-strip.

30



Snap T-mull base plate cap over base plate to finish off mullion.

31

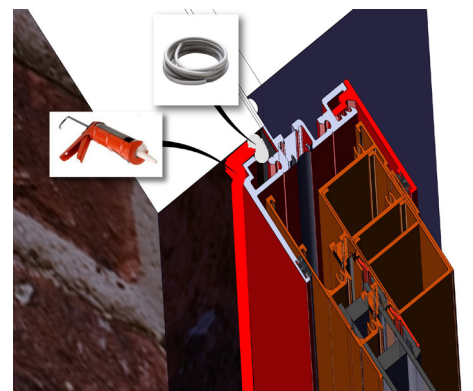
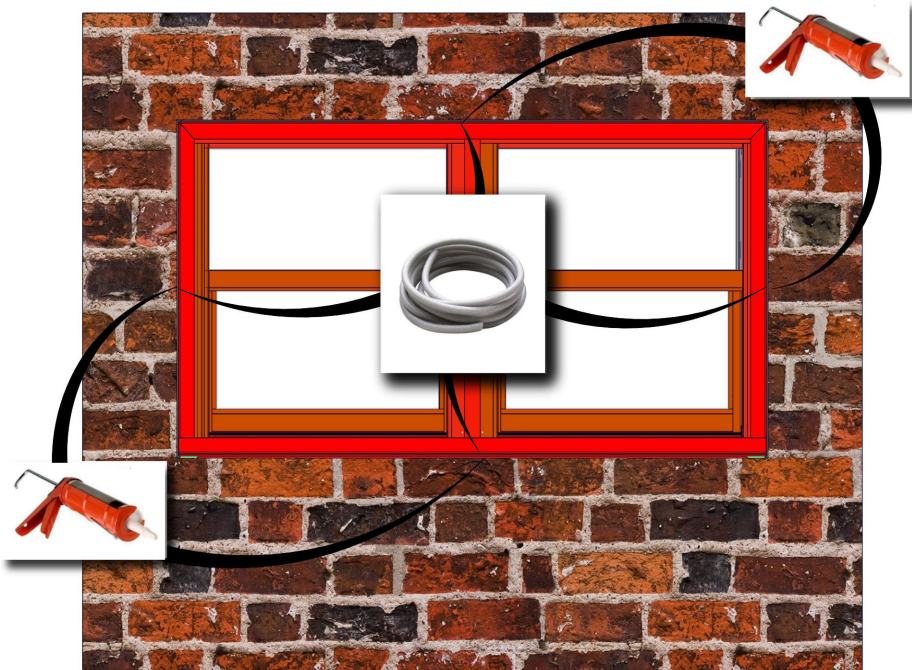

After siding or wall exterior is complete, apply backer rod and sealant between the window frame and exterior finish material on all four sides of unit. Make sure to clean all surfaces before applying sealant.



Installation Guidelines

For all Quaker Products With Flange Fin Sub-Sill and Receptor with T-mullion

If this set of instructions doesn't match your installation method or wall conditions please check our website listed below for other options, or call the office.

Scan here for a digital version of these guidelines in English



Or go to: <https://www.quakercommercialwindows.com/resources/installation-instructions-english/>

Scan here for a digital version of these guidelines in Spanish



Or go to: <https://www.quakercommercialwindows.com/installation-instructions-spanish/>

